

# Ruijie Reyee RG-ANT16S-120 Antenna

## Hardware Installation and Reference Guide



## Copyright

Copyright © 2024 Ruijie Networks

All rights are reserved in this document and this statement.

Any reproduction, excerpt, backup, modification, transmission, translation or commercial use of this document or any portion of this document, in any form or by any means, without the prior written consent of Ruijie Networks is prohibited.

Trademarks including  are owned by Ruijie Networks.

All other trademarks or registered trademarks mentioned in this document are owned by their respective owners.

## Disclaimer

The products, services, or features you purchase are subject to commercial contracts and terms. Some or all of the products, services or features described in this document may not be within the scope of your purchase or use. Unless otherwise agreed in the contract, Ruijie Networks does not make any express or implied statement or guarantee for the content of this document.

Due to product version upgrades or other reasons, the content of this document will be updated from time to time. Ruijie Networks reserves the right to modify the content of the document without any notice or prompt.

This manual is for reference only. Ruijie Networks endeavors to ensure content accuracy and will not shoulder any responsibility for losses and damages caused due to content omissions, inaccuracies or errors.

# Preface

## Audience

This document is intended for:

- Network engineers
- Technical support and servicing engineers
- Network administrators

## Technical Support

- Official Website of Ruijie Reyee: <https://reyee.ruijie.com>
- Technical Support Website: <https://reyee.ruijie.com/en-global/support>
- Case Portal: <https://www.ruijienetworks.com/support/caseportal>
- Community: <https://community.ruijienetworks.com>
- Technical Support Email: [service\\_rj@ruijienetworks.com](mailto:service_rj@ruijienetworks.com)
- Online Robot/Live Chat: <https://reyee.ruijie.com/en-global/rita>

## Conventions

### 1. GUI Symbols

| Interface symbol | Description  | Example  |
|------------------|--|--|
| Boldface         | 1. Button names<br>2. Window names, tab name, field name and menu items<br>3. Link | 1. Click OK.<br>2. Select Config Wizard.<br>3. Click the Download File link. |
| >                | Multi-level menus items  | Select System > Time.  |

### 2. Signs

The signs used in this document are described as follows:

---

#### Warning

An alert that calls attention to important rules and information that if not understood or followed can result in data loss or equipment damage.

---

---

#### Caution

An alert that calls attention to essential information that if not understood or followed can result in function failure or performance degradation.

---

---

 Note

An alert that contains additional or supplementary information that if not understood or followed will not lead to serious consequences.

---

---

 Specification

An alert that contains a description of product or version support.

---

**3. Note**

This document provides the installation steps, troubleshooting, technical specifications, as well as the specifications and use guidelines of cables and connectors. It is intended for users who want to understand the above contents, and are familiar with the installation and maintenance of networking hardware.

# Contents

|  |   |
|--|---|
| Preface .....                                  | I |
| 1 Product Introduction .....                   | 1 |
| 1.1 Overview .....                             | 1 |
| 1.2 Package Contents.....                      | 1 |
| 1.3 Product Appearance .....                   | 2 |
| 1.3.1 Appearance.....                          | 2 |
| 1.3.2 Antenna Connectors .....                 | 3 |
| 1.4 Specifications.....                        | 4 |
| 2 Preparing for Installation .....             | 6 |
| 2.1 Safety Precautions.....                    | 6 |
| 2.1.1 General Safety Precautions.....          | 6 |
| 2.1.2 Handling Safety.....                     | 6 |
| 2.1.3 Electrical Safety .....                  | 6 |
| 2.2 Installation Environment Requirements..... | 7 |
| 2.2.1 Environment.....                         | 7 |
| 2.2.2 Surge Protection .....                   | 7 |
| 2.2.3 Temperature and Humidity.....            | 7 |
| 2.2.4 Anti-Interference.....                   | 7 |
| 2.3 Tools .....                                | 8 |
| 2.4 Checking Before Installation .....         | 8 |
| 3 Installation .....                           | 9 |
| 3.1 Installation Procedure .....               | 9 |
| 3.2 Before You Begin.....                      | 9 |

|   |    |
|---|----|
| 3.3 Safety Precautions During Installation .....    | 10 |
| 3.4 Installation Procedures .....                   | 10 |
| 3.4.1 Installing the Wireless Bridge .....          | 10 |
| 3.4.2 Removing the Wireless Bridge .....            | 12 |
| 3.4.3 Installing the Antenna.....                   | 14 |
| 3.5 Connecting Cables.....                          | 16 |
| 3.6 Verifying the Installation.....                 | 16 |
| 4 Debugging .....                                   | 17 |
| 4.1 Setting Up the Configuration Environment .....  | 17 |
| 4.2 Checking Environment Before/After Power-on..... | 17 |
| 5 Monitoring and Maintenance.....                   | 18 |
| 5.1 Monitoring .....                                | 18 |
| 5.2 Hardware Maintenance.....                       | 18 |
| 6 Common Troubleshooting .....                      | 19 |
| 6.1 Troubleshooting Flowchart .....                 | 19 |
| 7 Appendix.....                                     | 20 |
| 7.1 Connectors and Media.....                       | 20 |

# 1 Product Introduction

## 1.1 Overview

The RG-ANT16S-120 antenna is an external sector antenna launched by Ruijie Reyee for outdoor bridges. This antenna, featuring the 5 GHz 2x2 MIMO technology and two spatial streams, delivers a gain of up to 16 dBi, with a horizontal angle of 120° and a vertical angle of 10°. It is specifically designed for the RG-AirMetro550G-B bridge for PTMP scenarios, covering a range of up to 5 km.

## 1.2 Package Contents

**Table 1-1 Package Contents**

| No. | Item  | Qty |
|-----|---|-----|
| 1   | RG-ANT16S-120 Antenna (with Mounting Bracket) | 1   |
| 2   | Protective Cover                              | 1   |
| 3   | RF Cable                                      | 2   |
| 4   | User Manual                                   | 1   |
| 5   | U Bracket                                     | 1   |
| 6   | Pole Bracket                                  | 1   |
| 7   | Pole Clamp                                    | 1   |
| 8   | Hexagon Flange Nut                            | 6   |
| 9   | Phillips Hexagon Flange Bolt                  | 2   |
| 10  | Cup Head Square Neck Bolt with Large Head     | 2   |

### Note

The package contents above are intended to provide a general overview, and are subject to the terms of the order contract. Please check your goods carefully against the package contents or order contract. If you have any questions, please contact the distributor.

## 1.3 Product Appearance

### 1.3.1 Appearance

Figure 1-1 Appearance

Front view



Back view





**i** Note

The label is located on the back of the device.

### 1.3.2 Antenna Connectors

Figure 1-2 Antenna Connectors

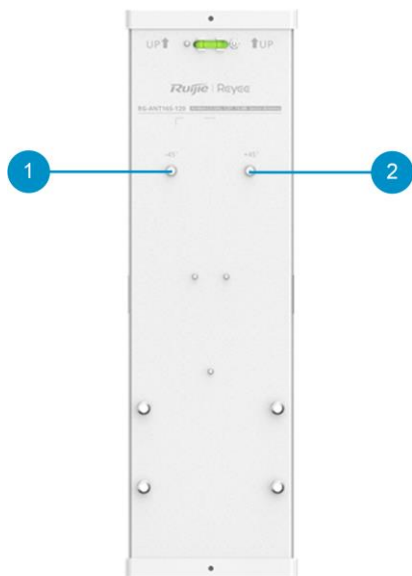

Table 1-2 Antenna Connectors

| Mark | Item | Description              |
|------|------|--------------------------|
| 1    | -45° | Antenna path 1 connector |
| 2    | +45° | Antenna path 2 connector |

## 1.4 Specifications

**Table 1-3 Specifications**

|                            |  |
|----------------------------|--|
| <b>Dimensions</b>          | 361 mm x 110 mm x 48.5 mm (14.21 in. x 4.33 in. x 1.91 in.) (excluding mounting bracket) |
| <b>Weight</b>              | 2.5 kg (5.51 lbs.) (including packaging)   |
| <b>Frequency Range</b>     | 5.15 - 5.85 GHz  |
| <b>Gain</b>                | 16 dBi   |
| <b>HPOL Beamwidth</b>      | 118° (6 dB)  |
| <b>VPOL Beamwidth</b>      | 120° (6 dB)  |
| <b>Elevation Beamwidth</b> | 10° (6 dB)   |
| <b>Electrical Downtilt</b> | 0°   |
| <b>Max. VSWR</b>           | 2.0:1  |
| <b>Wind Survivability</b>  | 220.32 km/h (137 mph)  |
| <b>Wind Loading</b>        | 93 N @ 220.32 km/h (20.9 lbf @137 mph)   |
| <b>Polarization</b>        | ±45°   |
| <b>Cross-Pol Isolation</b> | 20 dB Min.   |
| <b>Environment</b>         | Operating temperature: -40°C - 80°C (-40°F - 176°F)                                      |
|                            | Storage temperature: -40°C - 85°C (-40°F - 185°F)  |
|                            | Operating humidity: 5% - 95% (non-condensing)  |
|                            | Storage humidity: 5% - 95% (non-condensing)  |
| <b>Mounting</b>            | Pole-mount   |
| <b>IP Rating</b>           | IP55   |
| <b>Certification</b>       | CE   |
| <b>MTBF</b>                | > 400000 hours   |

 **Note**

The weight in the table refers to the weight of a single antenna.

 **Warning**

Operation of this equipment in a residential environment could cause radio interference.

---

# 2 Preparing for Installation

## 2.1 Safety Precautions

---

**Note**

- To prevent device damage and physical injury, please read carefully the safety precautions described in this chapter.
  - The following safety precautions do not cover all possible dangers.
- 

### 2.1.1 General Safety Precautions

- Do not expose the device to high temperature, dusts, or harmful gases. Do not install the device in an inflammable or explosive environment. Keep the device away from EMI sources such as large radar stations, radio stations, and substations. Do not subject the device to unstable voltage, vibration, and noises.
- The installation site should be far away from the sea. Keep the device at least 500 meters (1640 ft.) away from the seaside and do not face it toward the wind from the sea.
- The installation site should be free from water flooding, seepage, dripping, or condensation. The installation site shall be selected according to network planning and features of communications device, and considerations such as climate, hydrology, geology, earthquake, electric power, and transportation.

---

**Caution**

Please follow the correct procedures described in this guide to install and remove the device.

---

### 2.1.2 Handling Safety

- Avoid frequently handling the device.
- Cut off all the power supplies and unplug all power cords before moving or handling the device.

### 2.1.3 Electrical Safety

---

**Warning**

- Improper or incorrect electrical operations may cause a fire, electric shock, and other accidents, and lead to severe and fatal personal injury and device damage.
  - Direct or indirect contact with high voltage or mains power supply via wet objects may cause fatal dangers.
- 

- Observe local regulations and specifications during electrical operations. Only personnel with relevant qualifications can perform such operations.
- Check whether there are potential risks in the work area. For example, check whether the power supply is grounded, whether the grounding is reliable, and whether the ground is wet.

## 2.2 Installation Environment Requirements

To ensure normal operation and a prolonged service life of the device, the installation site must meet the following requirements.

### 2.2.1 Environment

- Install the device in a well-ventilated environment. If it is installed in a closed room, make sure there is a good cooling system.
- Make sure the site is sturdy enough to support the device and its accessories.
- Make sure the site has enough space for installing the device and leave sufficient space around the device for ventilation.

### 2.2.2 Surge Protection

- When the connection cable between the main grounding conductor and local equipotential earthing terminal board (LEB) on each floor is short, use a stranded copper wire with a sectional area not less than 1.318 mm<sup>2</sup> (16 AWG) for the connection cable.
- Use a shielded network cable if possible. Ensure that devices connected to both ends of the shielded network cable are reliably grounded, and that the sheath of the shielded network cable is also grounded if possible. If no shielded network cable is available, wire the network cable through a steel pipe and bury the steel pipe for lead-in, and properly ground both ends of the steel pipe.
- The device has a built-in high-grade surge arrester with a 4KV surge protection capability. Generally, additional surge arrester is not required. If a higher surge protection level is required, a surge arrester can be installed and must be grounded.

### 2.2.3 Temperature and Humidity

To ensure the normal operation and prolonged service life of the device, maintain an appropriate temperature and humidity in the equipment room. The equipment room with too high or too low temperature and humidity for a long period may damage the device.

- In an environment with high humidity, the insulating material may have bad insulation or even leak electricity and sometimes the materials may suffer from mechanical performance change and metallic parts may get rusted.
- In an environment with low humidity, the insulating strip may dry and shrink, and static electricity is prone to occur and damage the internal circuits of the device.
- In an environment with high temperature, the device is subjected to even greater harm, as its performance may degrade significantly and its useful life may be shortened in the case of long-term exposure that expedites the aging process.

**Table 2-1 Temperature and Humidity Requirements**

| Operating Temperature            | Operating Humidity            |
|----------------------------------|-------------------------------|
| -40°C to +80°C (-40°F to +176°F) | 5% to 95% RH (non-condensing) |

### 2.2.4 Anti-Interference

- Take interference prevention measures for the power supply system.

- Keep the device away from the grounding facility or lightning and grounding facility of the power device as much as possible.
- Keep the device away from high-power radio stations, radar stations, and high-frequency high-current devices.

## 2.3 Tools

**Table 2-2 Tools**

|                         |  |
|-------------------------|--|
| <b>Common Tools</b>     | Marker, Phillips screwdriver, hammer drill, power cords, Ethernet cables, and diagonal plier                   |
| <b>Special Tools</b>    | Anti-ESD gloves, wire stripper, crimping plier, RJ45 crimping plier, wire cutter, and waterproof adhesive tape |
| <b>Meters</b>           | Multimeter   |
| <b>Relevant Devices</b> | PC, display, and keyboard  |

---

 **Note**

RG-ANT16S-120 is not shipped with a tool kit. You need to prepare a tool kit by yourself.

---

## 2.4 Checking Before Installation

After unpacking the product, carefully inspect each item in accordance with the provided package contents. If any inconsistencies are found, please contact our local distributor.

# 3 Installation

## ⚠ Caution

Before installing the device, make sure that you have carefully read the requirements described in Chapter 2.

## 3.1 Installation Procedure

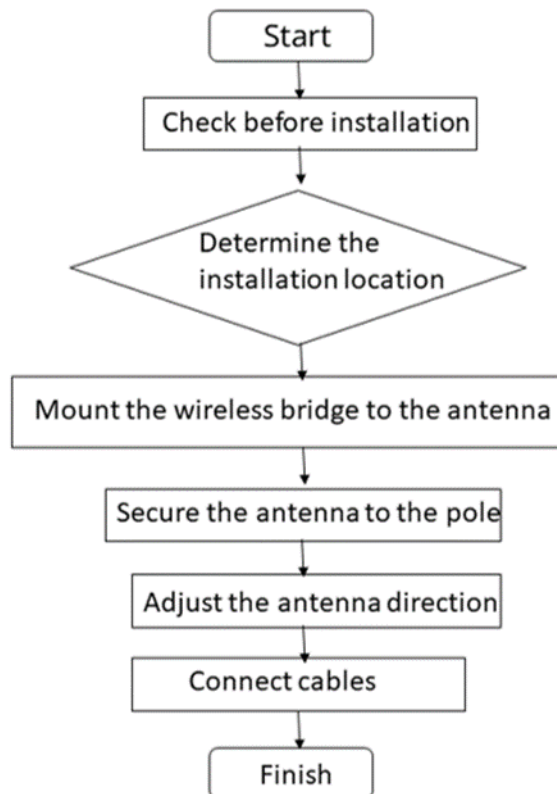

## 3.2 Before You Begin

Carefully plan and arrange the installation location, networking mode, power supply, and cabling of the device before installation. Confirm the following points before installation:

- The installation site provides sufficient space for heat dissipation.
- The installation site meets the temperature and humidity requirements of the device.
- The power supply and required current are available in the installation site.
- The selected power supply modules meet the system power requirement.
- The network cables have been deployed in the installation site.
- The installation site meets all requirements described in this guide.
- The device meets the customers' requirements.

### 3.3 Safety Precautions During Installation

To ensure minimal interference when installing multiple wireless bridges in close proximity, maintain a horizontal installation distance of at least 2 meters, or a vertical installation distance of at least 0.5 meters between each wireless bridge. Ensure that the horizontal angle formed by the two wireless bridges is greater than 120 degrees. The specific installation location of the wireless bridge should be determined by professionals after conducting a thorough site survey.

Before installation, ensure that the installation location meets the requirements in [2.2.1 .Environment](#) and pay attention to the following:

- Use the provided power adapter (24 V, 0.5 A PoE power adapter, with positive on pins 4 and 5 and negative on pins 7 and 8), or an alternative power supply with identical specifications to supply power to this device. Do not use power adapters with different specifications.
- The supplied PoE adapter supports Cat5e or better Ethernet cables for power supply for up to 100 meters (328 ft.). Prior to connecting the Ethernet cable, ensure that the power module switch is in the off position.
- Ensure the Ethernet cables and power cords are securely connected.

### 3.4 Installation Procedures

---

 **Caution**

- Install the device in a manner that maximizes the coverage area of the antenna.
  - The schematic diagram provided is for reference purposes only. The actual product should be installed based on its physical specifications and design.
- 

#### 3.4.1 Installing the Wireless Bridge

This wireless bridge can be mounted onto 90°, 120°, or 360° antennas. The installation procedure is the same. The following section describes the installation procedure for the 90° antenna.

- (1) Connect the RF cable to the SMA connector of the wireless bridge.



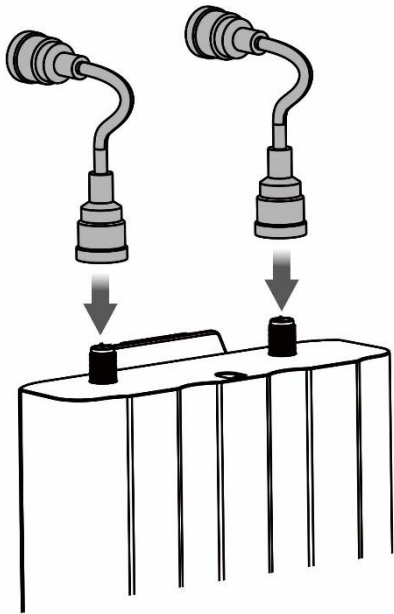

(2) Attach the wireless bridge to the antenna.

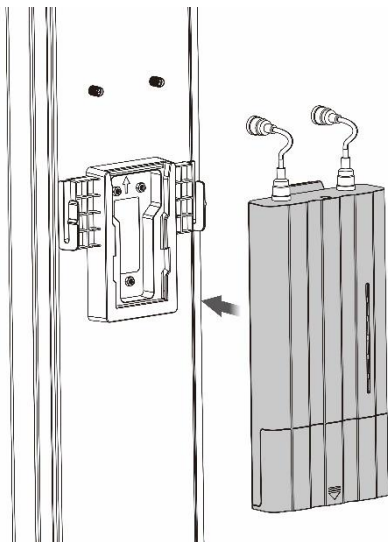

(3) Connect the SMA connector of the wireless bridge to that of the antenna.

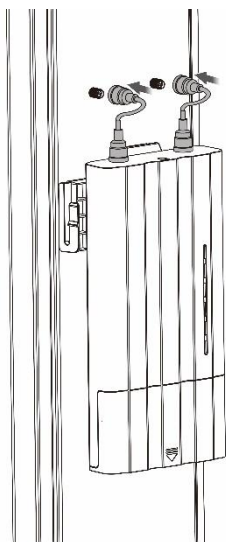

- (4) Install the protective cover.

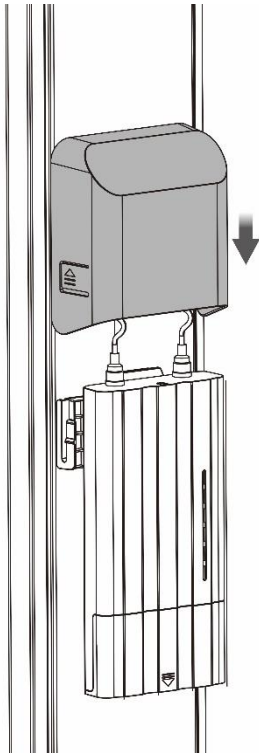

### 3.4.2 Removing the Wireless Bridge

- (1) Remove the protective cover by pulling it upward.

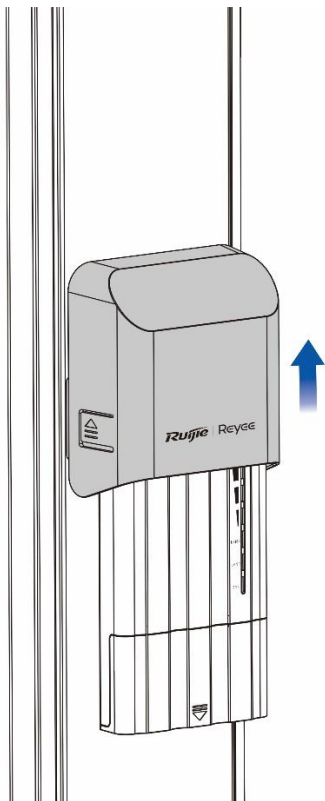

- (2) Unscrew the RF cable.



(3) Remove the wireless bridge by pulling it upward and then outward.

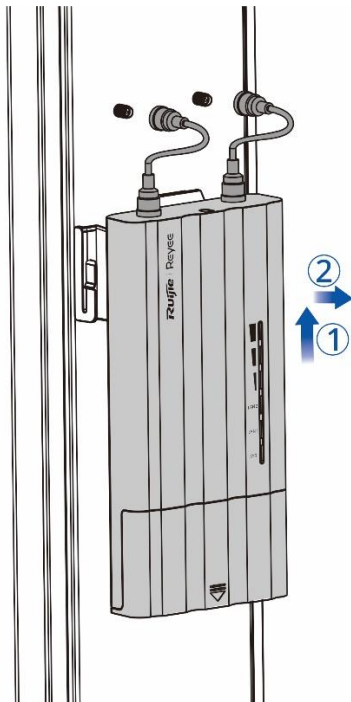

(4) Remove the RF cable.

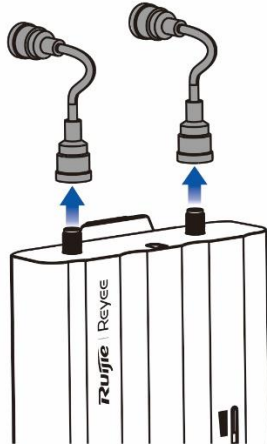

### 3.4.3 Installing the Antenna

**i** Note

You are advised to use the following three Ruijie antenna models: RG-ANT20S-90, RG-ANT16S-120, and RG-ANT13-360.

- Installing a 120° antenna

(1) Secure the mounting bracket to the antenna with four screws.

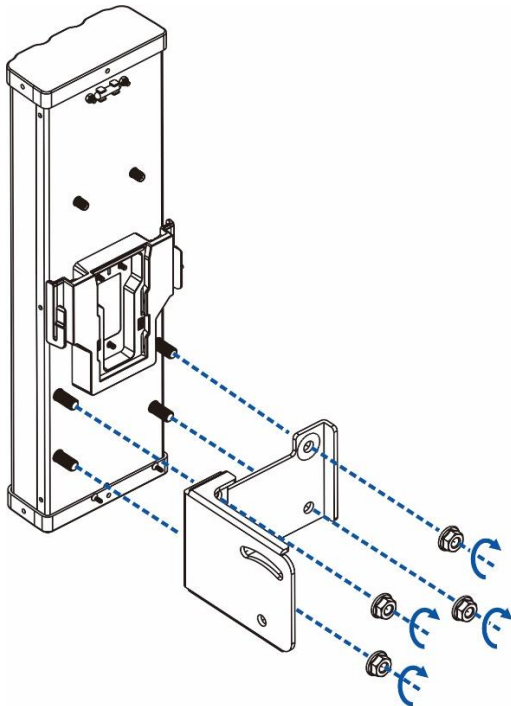

(2) Attach the bracket holder to the bracket with two screws.

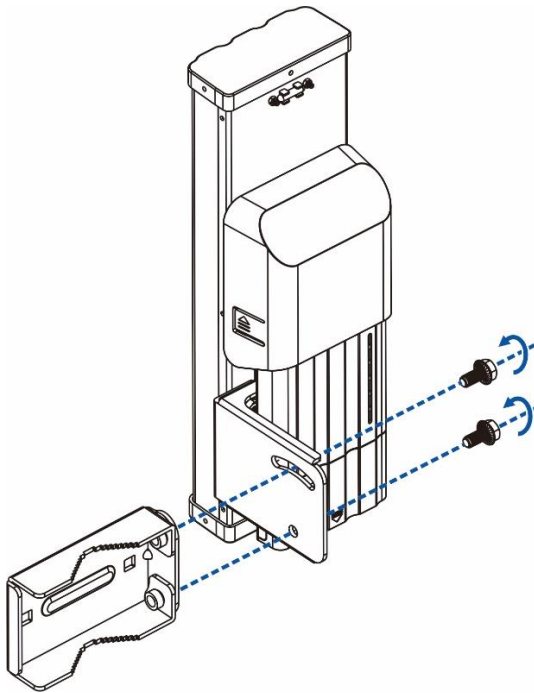

(3) Secure the antenna to the pole.

**i** Note

M8 x 150 mm screws are recommended.

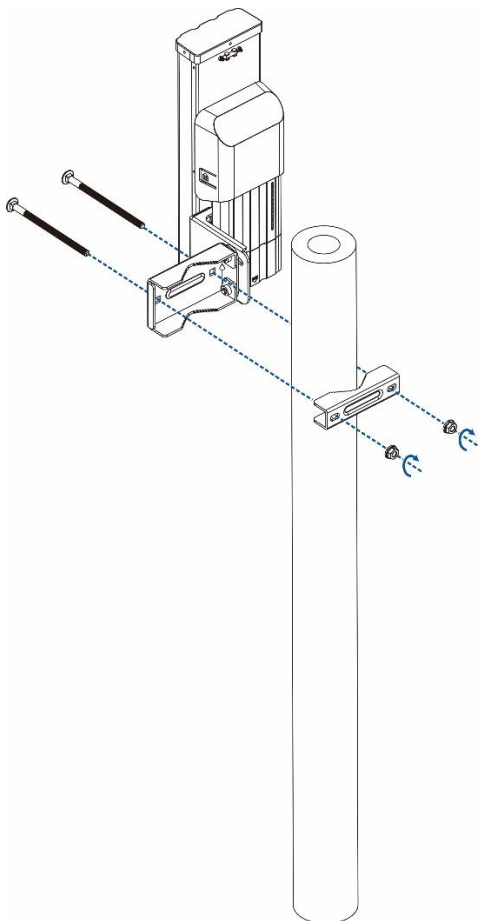

## 3.5 Connecting Cables

- (1) Use or make an Ethernet cable based on the distance between the wireless bridge and the power source. The device supports PoE power supply over Cat5e or better cables with a cable length up to 100 meters (328 ft.).
- (2) Connect the PoE port of the 24 V PoE adapter to the LAN1/PoE port of the wireless bridge using an Ethernet cable. Connect the LAN port of the PoE adapter to the server or camera using another Ethernet cable. Alternatively, connect the 12 V DC adapter to the DC port of the wireless bridge for power supply, and then connect the LAN port of the wireless bridge to the server or camera using another Ethernet cable.

**Figure 3-1 Cable Connection**

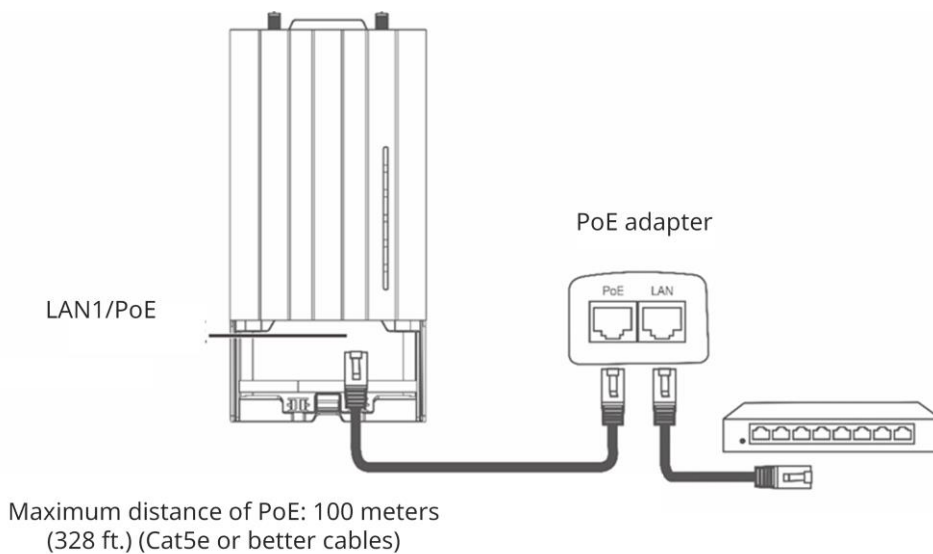

---

**Warning**

- After the Ethernet cable is securely connected to the device, cover the device with a waterproof cover to shield it from potential water and dust damage.
  - Do not use other models of PoE adapters or switches for power supply as it may lead to irreparable damage to the device.
- 

## 3.6 Verifying the Installation

- (1) Check the device
  - Verify that the external power supply matches the device.
  - Verify that the device is firmly and reliably secured.
- (2) Check the power supply
  - Verify that the power cord is properly connected and meet safety requirements.
  - Turn on the power supply to supply power to the device. Verify that the device works properly.

# 4 Debugging

## 4.1 Setting Up the Configuration Environment

Before setting up the configuration environment using the 24 V, 0.5 A PoE power supply or the 12 V DC power supply, verify that the power cord is properly connected and that the configuration environment meets safety requirements.

## 4.2 Checking Environment Before/After Power-on

(1) Before power-on, check the following:

- Verify that the power supply is properly connected.
- Verify that the input voltage matches the specification.

(2) After power-on, check the following (Recommended):

- Verify that the LED status is normal.

# 5 Monitoring and Maintenance

## 5.1 Monitoring

You can observe the LED status to monitor the device in operation.

## 5.2 Hardware Maintenance

If the hardware is faulty, please contact Ruijie Networks technical support for assistance.



# 6 Common Troubleshooting

## 6.1 Troubleshooting Flowchart

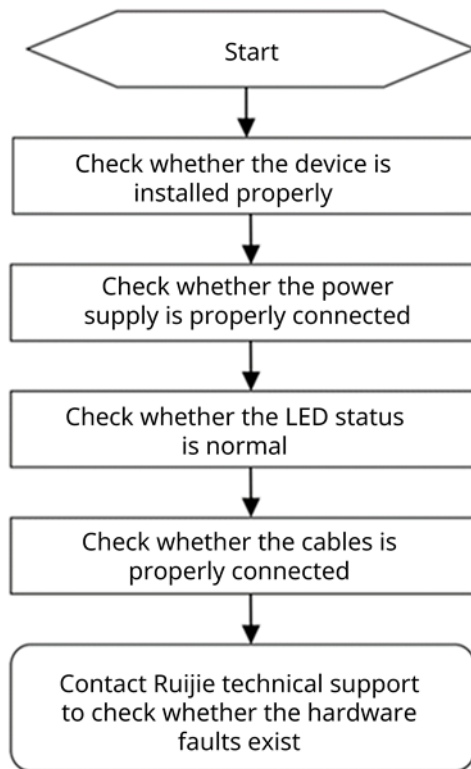

# 7 Appendix

## 7.1 Connectors and Media

### 1000BASE-T/100BASE-TX/10BASE-T Port

The 1000BASE-T/100BASE-TX/10BASE-T port is a 10/100/1000 Mbps auto-negotiation port that supports auto MDI/MDIX Crossover.

Compliant with IEEE 802.3ab, the 1000BASE-T port requires Category 5e 100-ohm UTP or STP (recommended) with a maximum distance of 100 meters (328 feet).

The 1000BASE-T port requires all four pairs of wires to be connected for data transmission. The following figure shows the four pairs of wires for the 1000BASE-T port.

**Figure 7-1 1000BASE-T Twisted Pair Connections**

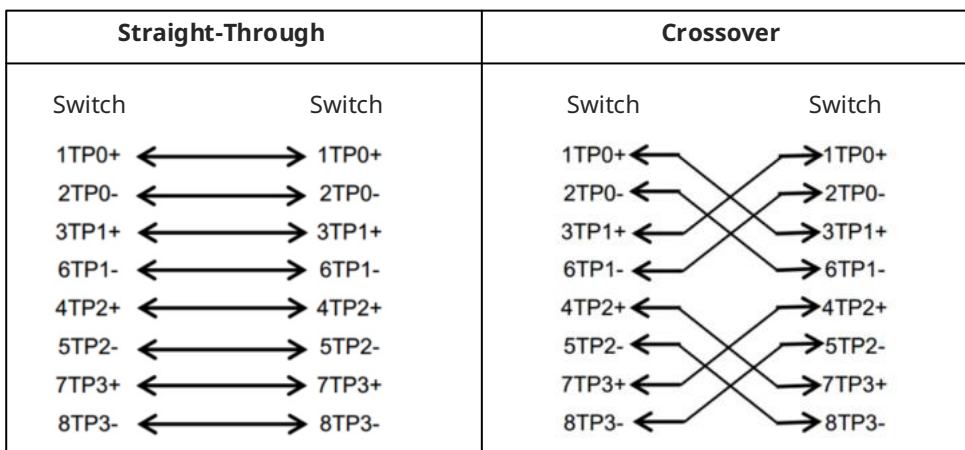

100BASE-TX/10BASE-T can be interconnected using cables of the preceding specifications. For 10 Mbps, the 100BASE-TX/10BASE-T port can be connected using 100-ohm Category 3, Category 4, and Category 5 cables; for 100 Mbps, the 100BASE-TX/10BASE-T port can be connected using 100-ohm Category 5 cables with a maximum connection distance of 100 meters. The following table shows 100BASE-TX/10BASE-T pin assignments.

**Table 7-1 100BASE-TX/10BASE-T Pin Assignments**

| Pin        | Socket                | Plug                  |
|------------|-----------------------|-----------------------|
| 1          | Input Receive Data+   | Output Transmit Data+ |
| 2          | Input Receive Data-   | Output Transmit Data- |
| 3          | Output Transmit Data+ | Input Receive Data+   |
| 6          | Output Transmit Data- | Input Receive Data-   |
| 4, 5, 7, 8 | Not Used              | Not Used              |

The following figure shows feasible connections of the straight-through and crossover twisted pair cables for a 100BASE-TX/10BASE-T port.

**Figure 7-2 100BASE-TX/10BASE-T Twisted Pair Connections**

